

MODEL 95



High Performance Plastic Commercial Pool Pump

Features

- Largest one-piece housing design with integrated strainer basket and easy on/off two piece lid.
- Quiet and efficient medium head pump performance.
- This high performance pump comes complete with our unique mechanical shaft seal that allows the pump, if mistreated, to run dry for up to one hour.
- The pump can be used for pool water with a salt concentration of up to 5000 ppm.
- Suction and discharge are equipped with 4" quick disconnect unions for easy installation and maintenance.
- Wrench for unions and lid is included with each pump. Flanges are available on request.
- Available with a heavy duty energy efficient totally enclosed fan cooled (TEFC) or Open Drip Proof (ODP) motor designs. (*Model 95-IX & Model 95-X requires a motor starter.*)
- Motor is easy to remove without disturbing the plumbing. Reusable o-rings throughout.
- Two year warranty on the motor and all pump parts, including normal wear of the mechanical seal.
- Every pump is performance tested before leaving the Speck factory.



Model 95-X



Trademarks and Certifications



Applications

- In-ground pools
- High rate sand filter applications
- Water Features

Dimensional Drawing

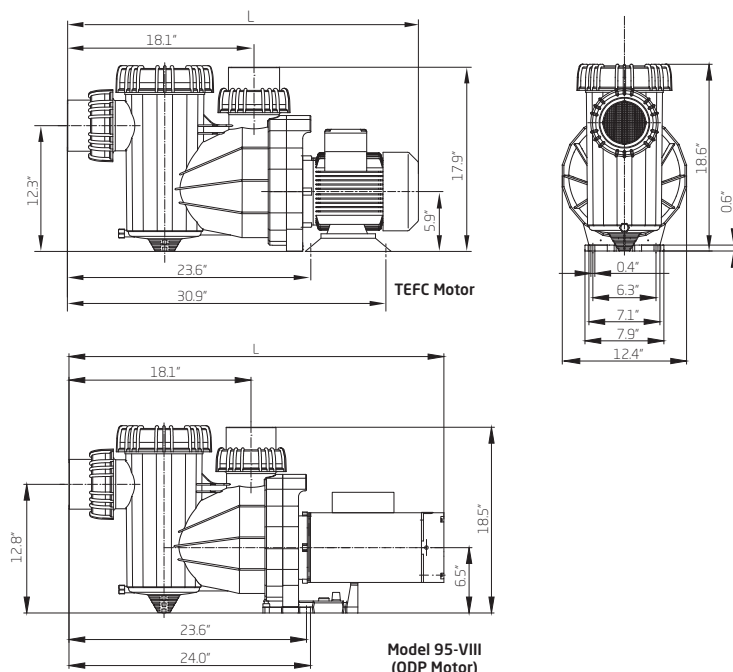

Performance Curves

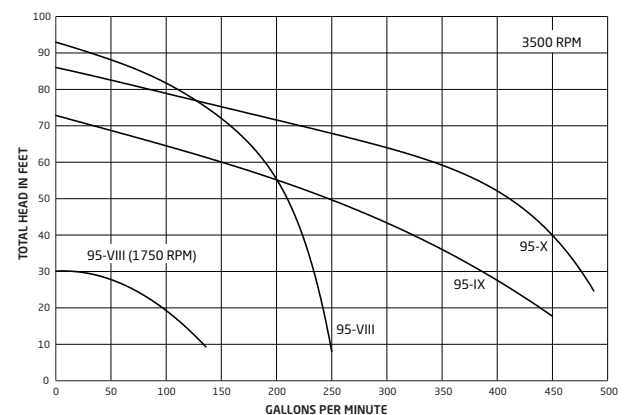

MODEL	DIMENSION "L"	SHIPPING WEIGHT
95-VIII	36.8"	75 lbs.
95-IX	36.5"	140 lbs.
95-IX (3PH)	34.0"	100 lbs.
95-X (3PH)	36.5"	141 lbs.